

ALPHA

Gamme Acier

PIVOTANTE

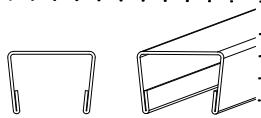

Traverse "U"
Finition acier laqué

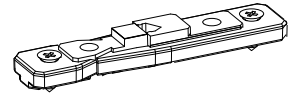

Crapaudine haute et basse

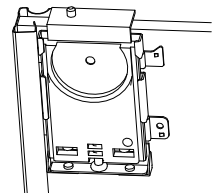

Pivot haut et bas
Réglage ± 5 mm

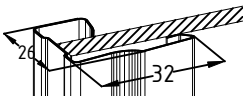

Profil Vertical: Acier laqué
ou enrobé



Bouton à encoche
(par défaut)

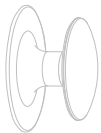

Bouton champignon
(par défaut si miroir)

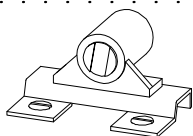

Loqueteau magnétique

- Panneaux: -Épaisseur 10 mm
- Mélaminé 2 faces E1
- Euroclasse d-s2,d0

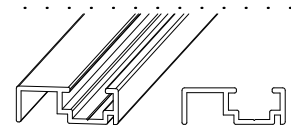

Rail haut & bas aluminium
anodisé ou laqué

DESCRIPTIF TECHNIQUE PORTES SUR MESURE

REPLISSAGE

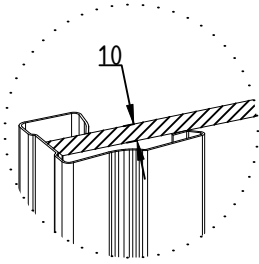

Panneau : épaisseur 10 mm
Hauteur Total maxi : 2790 mm
 mini : 400 mm
Largeur Vantail maxi : 800 mm
 mini : 350 mm

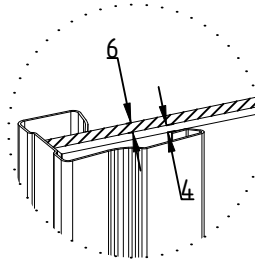

Vitre/Miroir : épaisseur 4 mm
Panneau : épaisseur 6 mm
Hauteur Total maxi : Fonction du vitrage
 mini : 400 mm
Largeur Vantail maxi : 800 mm
 mini : 350 mm

SENS D'OUVERTURE

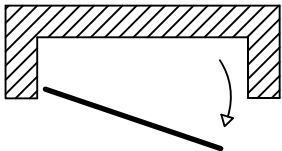

Tirant Gauche

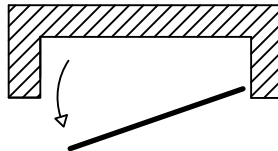

Tirant Droite

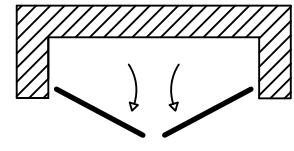

Tirant Double

DONNÉES TECHNIQUES

Vue: Perspective

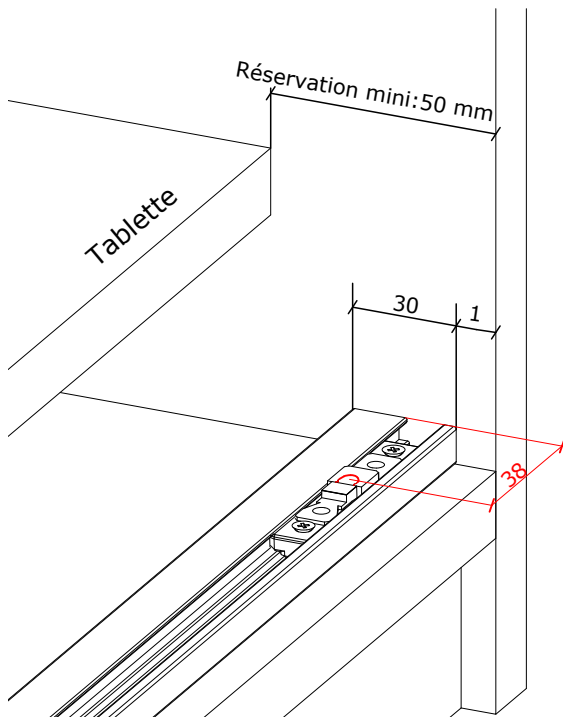

Vue: Dessus

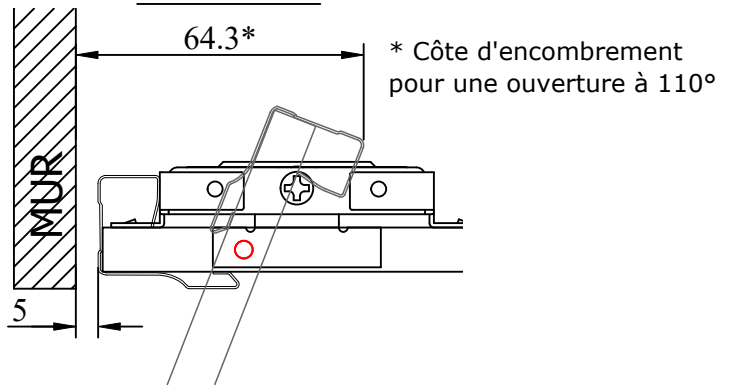

Vue: Coupe

