

OPEN ALTITUDE

A VUE D'ENSEMBLE - SYSTEME COULISSANT

Version sous plafond

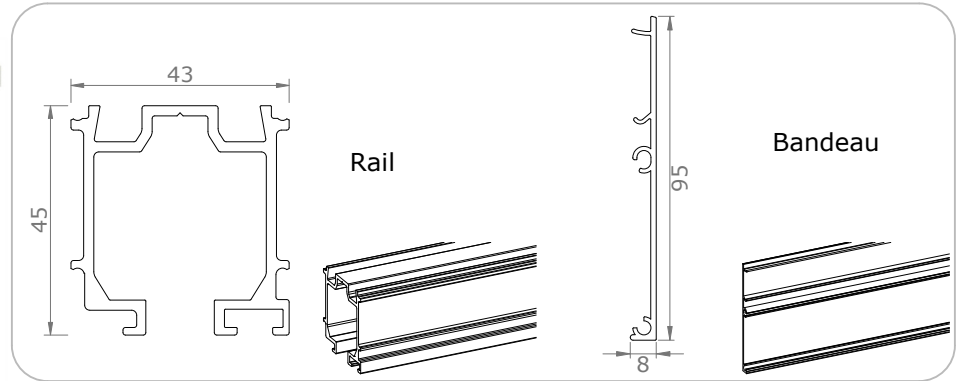

Version applique

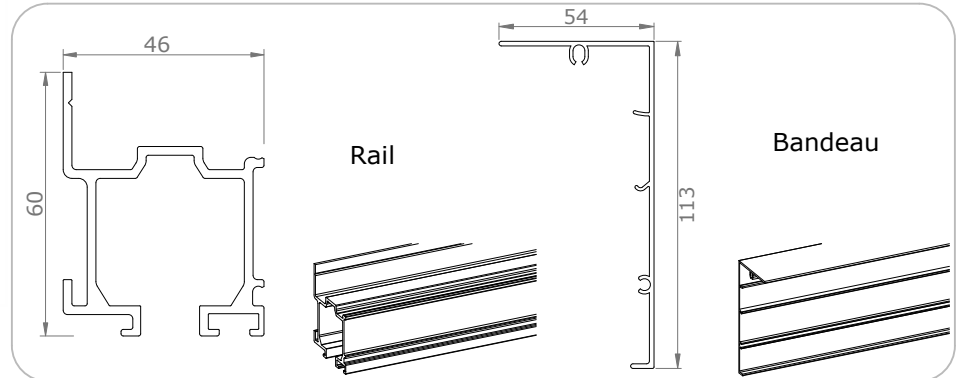

Attention au mode
de fixation utilisé

- Nos vantaux sont suspendus au rail grâce à nos chariot 4 roulettes
Les 2 chariots par vantail peuvent supporter un poids total par vantail allant jusqu'à 80 kg.
- Les déclencheurs sont positionnés pour déterminer la position d'arrêt du vantail
- Les butées sont une sécurité empêchant le vantail de sortir du rail
- Les entretoises sont mise en place sur le rail pour ensuite fixer le bandeau

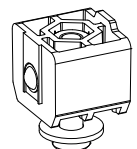
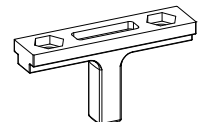
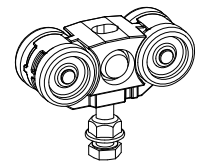

B VUE D'ENSEMBLE - VANTAIL

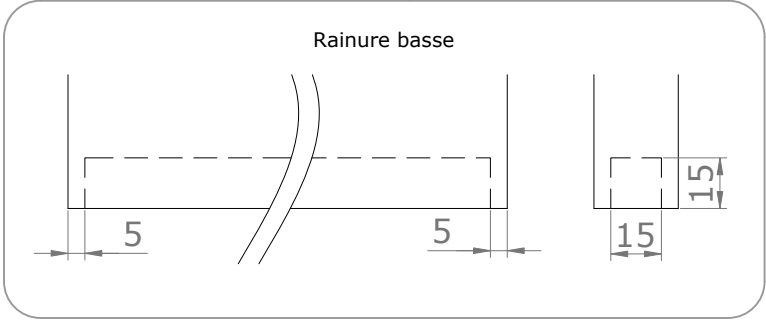
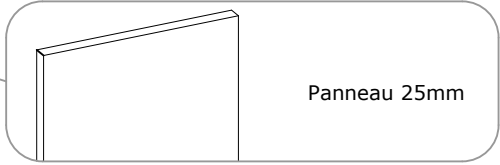
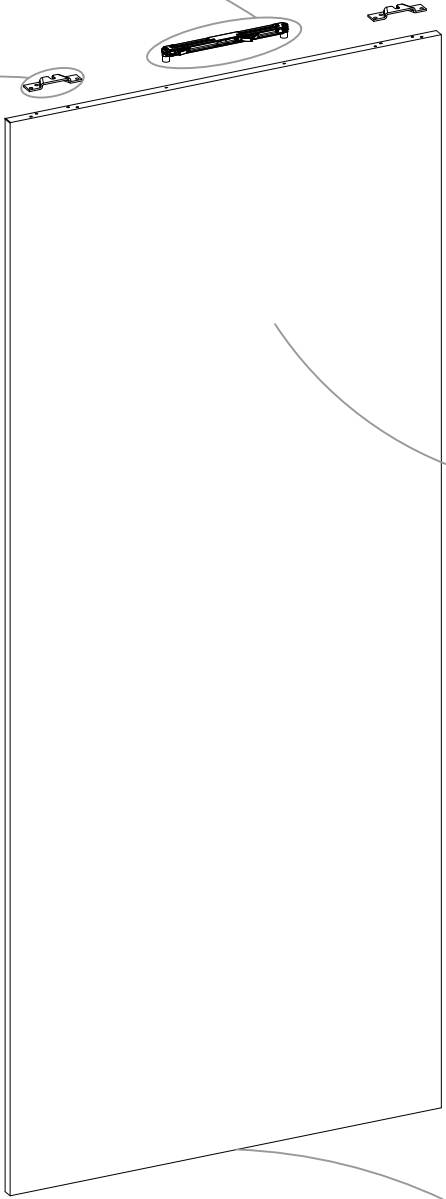
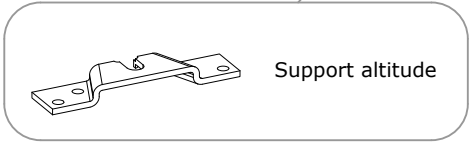
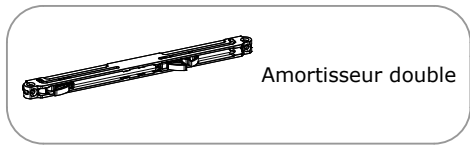

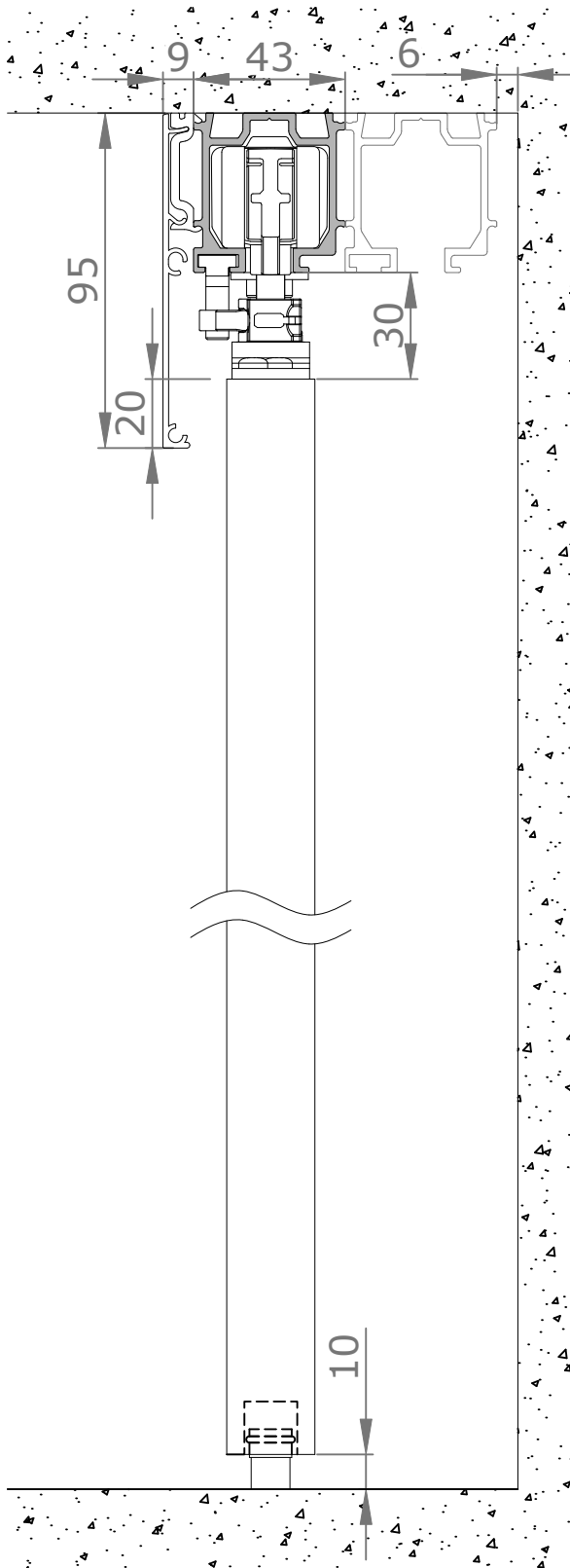
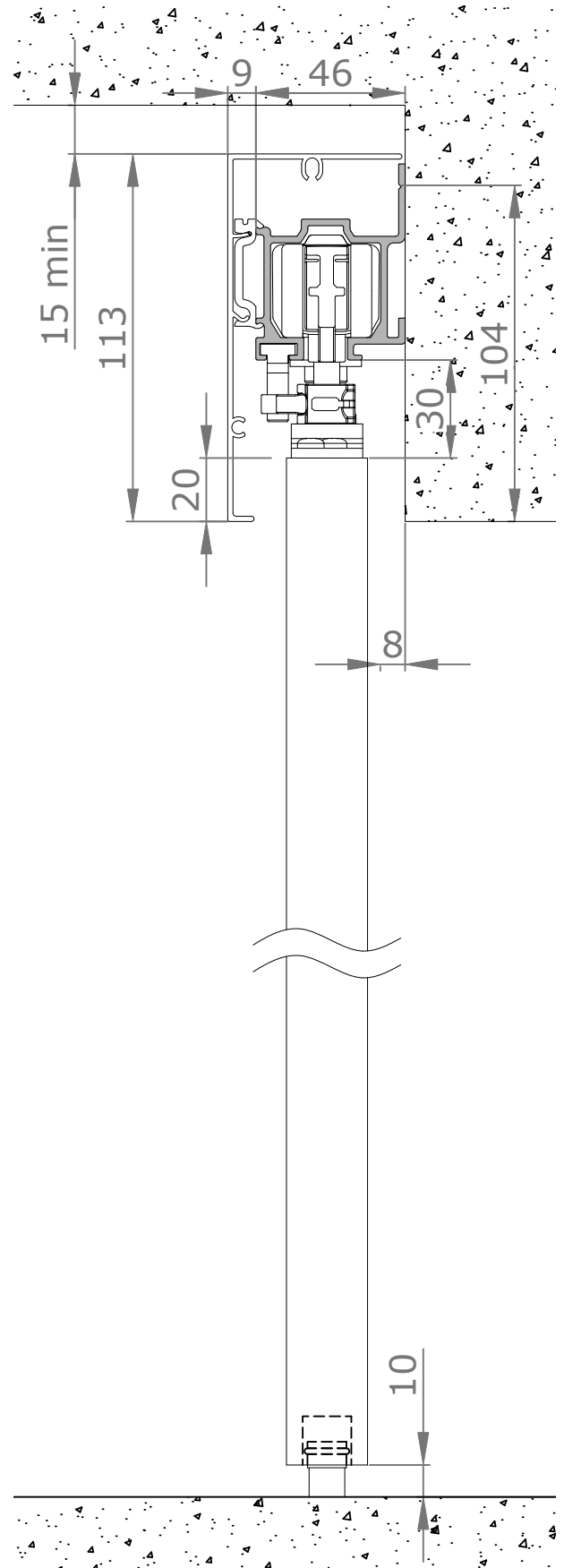
Version sous plafondVersion applique

D OPTION

Cale d'embout de rail :

1 rail, 1 bandeau sous plafond

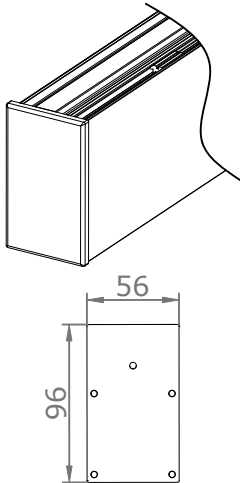

1 rail, 2 bandeaux sous plafond

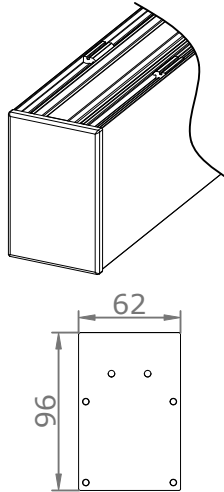

2 rails sous plafond

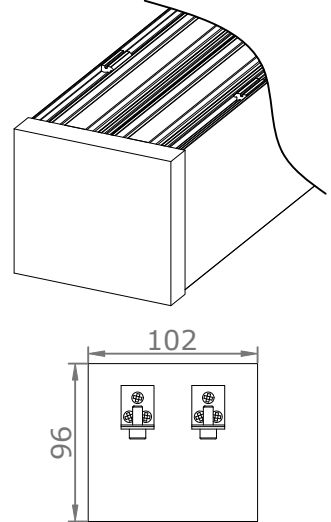

Rail et bandeau en applique

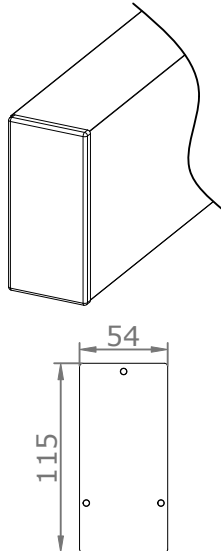

Poignée encastrée

