

## SEPARATION DE PIECE MARS

### A VUE D'ENSEMBLE - SYSTEME COULISSANT

#### Version sous plafond

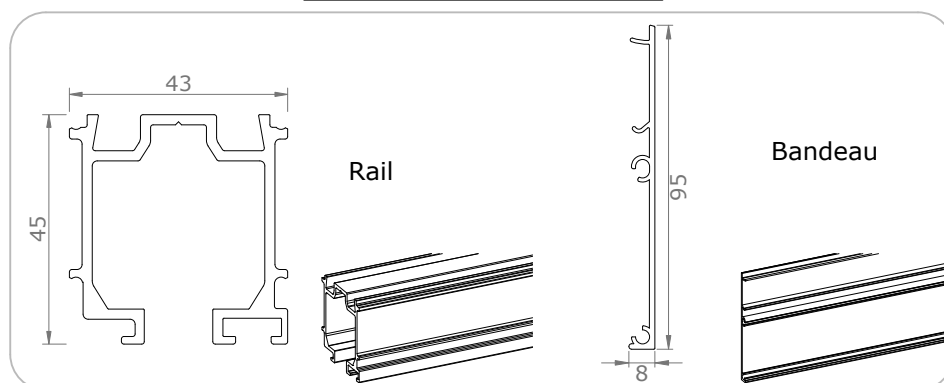

#### Version applique

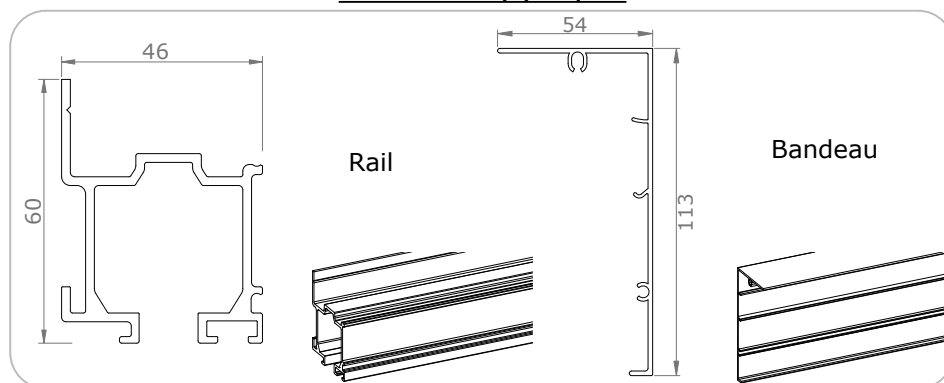

- Nos vantaux sont suspendus au rail grâce à nos chariot 4 roulettes  
Les 2 chariots par vantail peuvent supporter un poids total par vantail allant jusqu'à 80 kg.

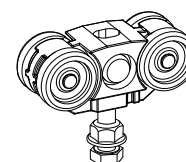

Poids du vantail en kg par m <sup>2</sup>			
Panneau 10 mm	1 face panneau 1 face vitre	Vitre 6.8 mm	vitre 4 mm
7	14	17	10

Attention au mode de fixation utilisé

- Les déclencheurs sont positionnés pour déterminer la position d'arrêt du vantail
- Les butées sont une sécurité empêchant le vantail de sortir du rail
- Les entretoises sont mise en place sur le rail pour ensuite fixer le bandeau

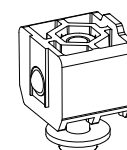
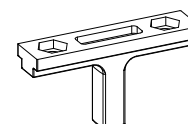

# B VUE D'ENSEMBLE - VANTAIL

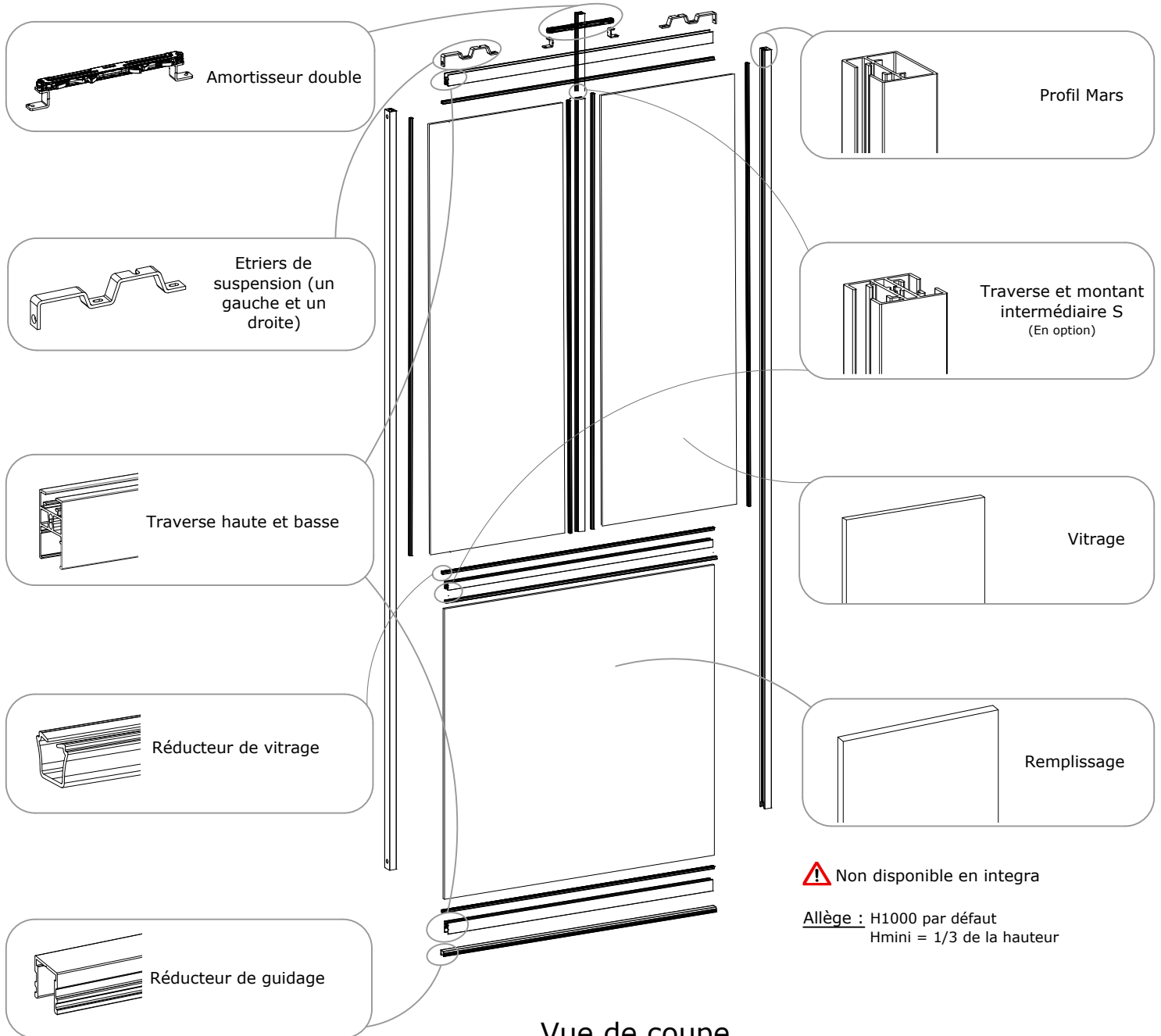

**⚠** Non disponible en integra

Allège : H1000 par défaut  
Hmini = 1/3 de la hauteur

## Vue de coupe

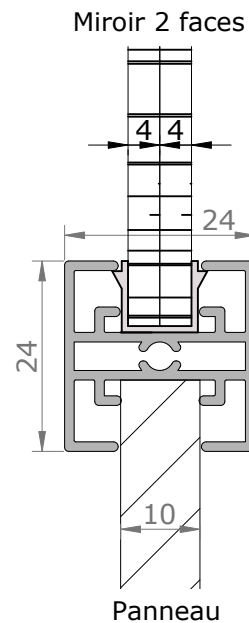
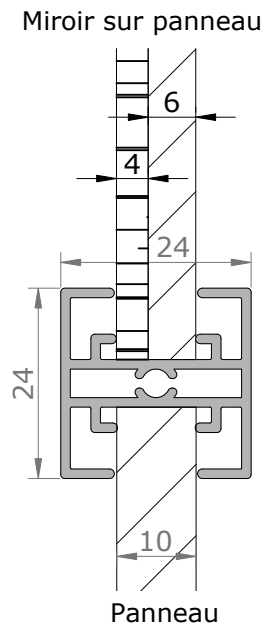
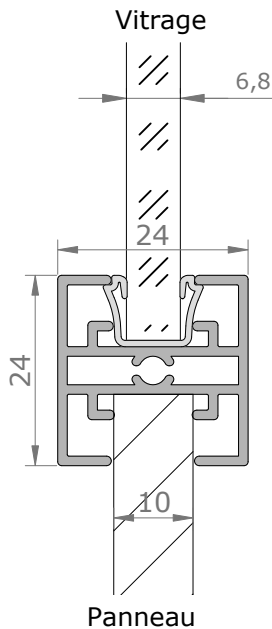

Version sous plafond

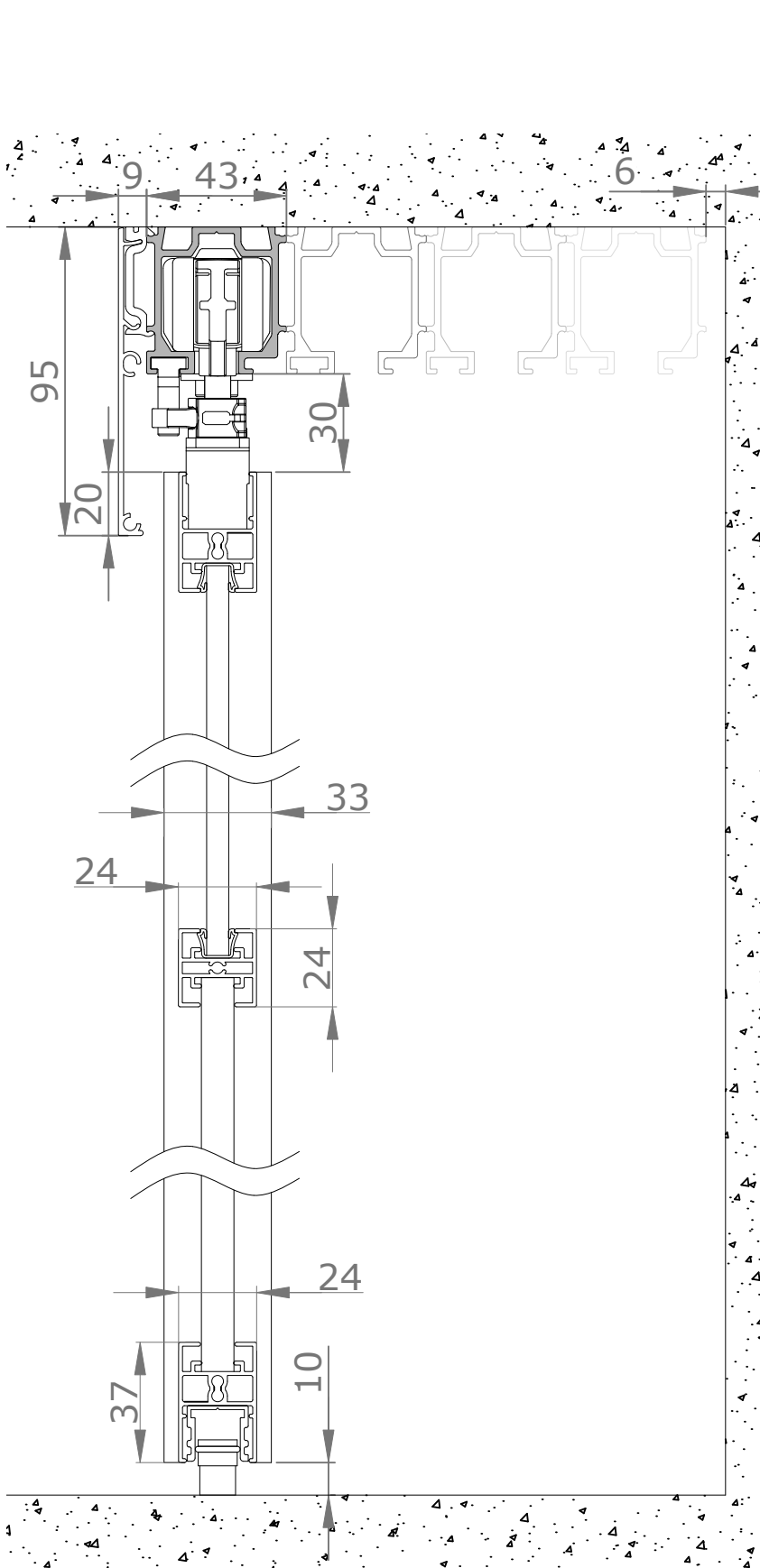

Version applique

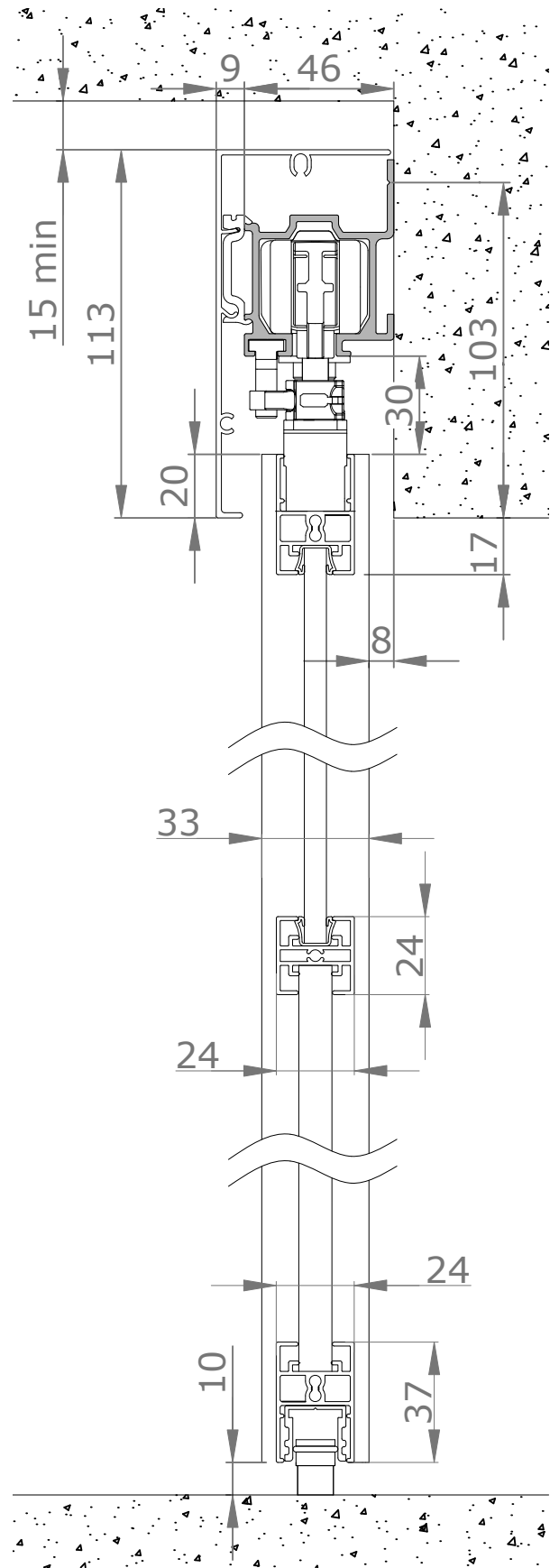

### Cale d'embout de rail Aluminium :

1 rail, 1 bandeau sous plafond

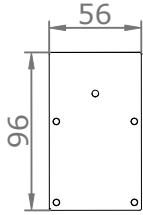
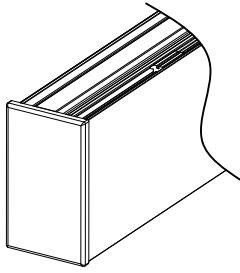

1 rail, 2 bandeaux sous plafond

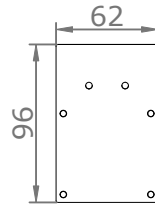
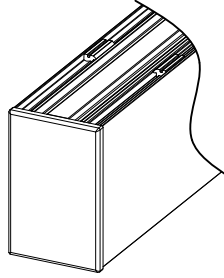

2 rails sous plafond

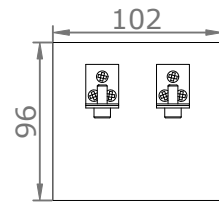
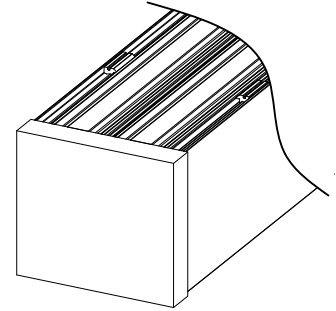

Rail et bandeau en applique

