

COULI-LIGHT - BARRE D'ECLAIRAGE LED A DETECTION AUTOMATIQUE

A OUTILS

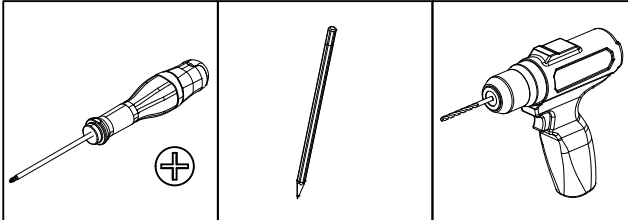

B CONTENU

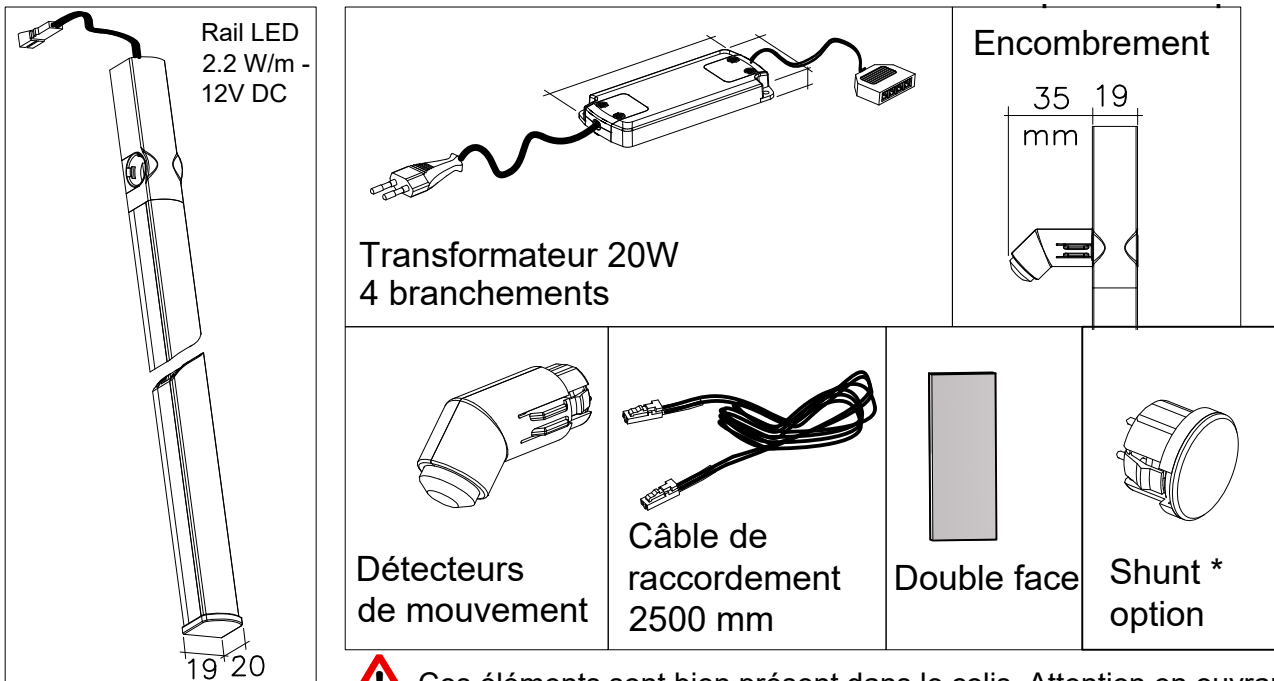

Ces éléments sont bien présent dans le colis. Attention en ouvrant le carton

C CONFIGURATIONS

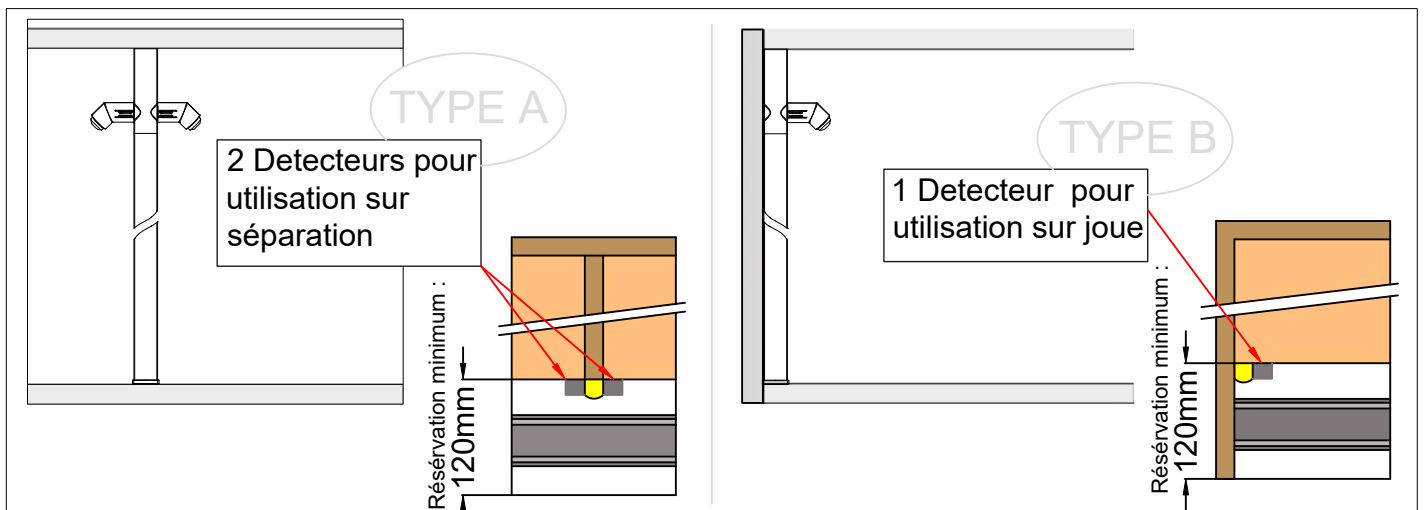

D MONTAGE

1 PREPARATION PASSAGE DE CÂBLE

Prevoir perçage $\varnothing 10\text{mm}$
sur tablette toit pour
passage de câble

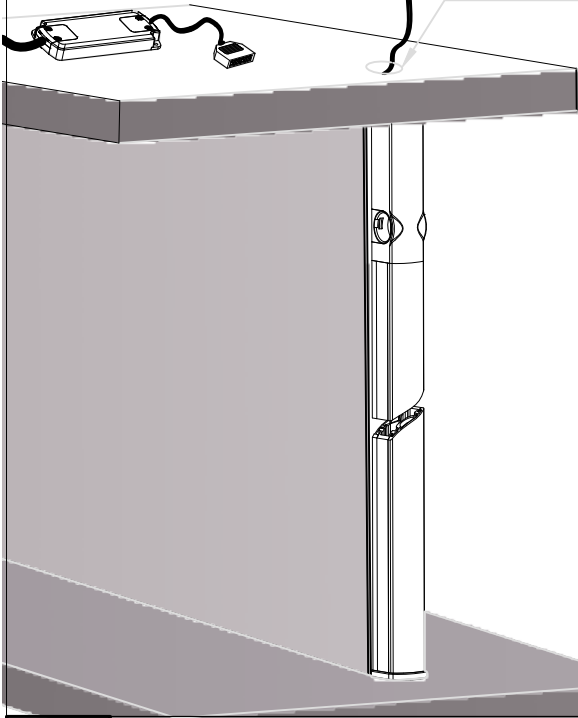

2 MISE EN PLACE SI PRESENCE DE RAIL



Il est conseillé de mettre en place
le système Couilight avant la
mise en place du rail haut

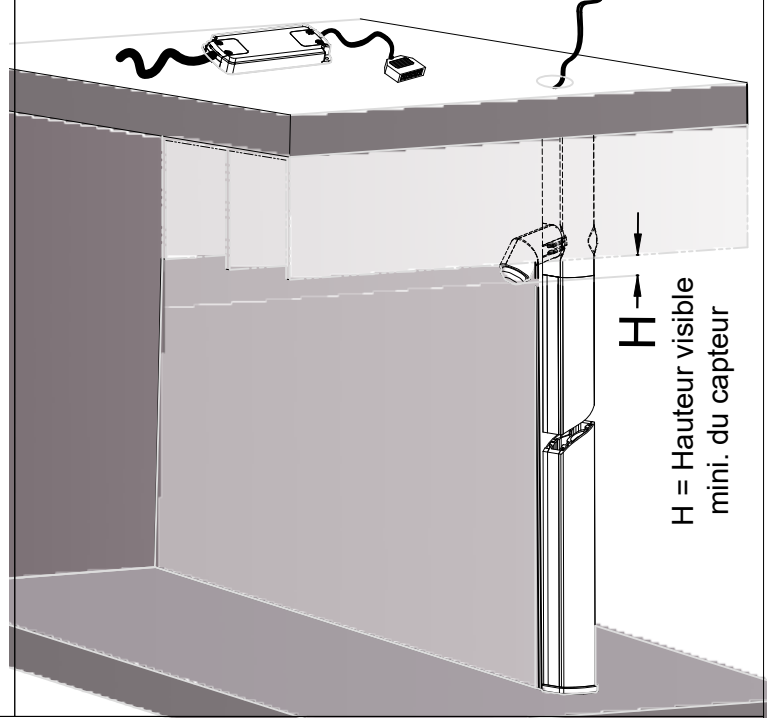

3-A MONTAGE DU COULILIGHT SUR SEPARATION (TYPE A)

INSTALLATION PAR VISSAGE

OU

INSTALLATION PAR DOUBLE FACE

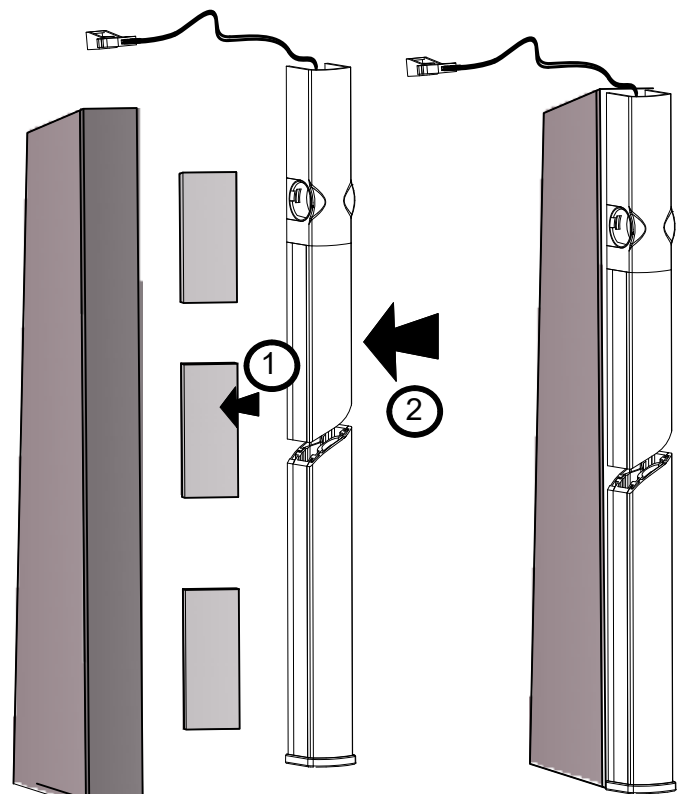
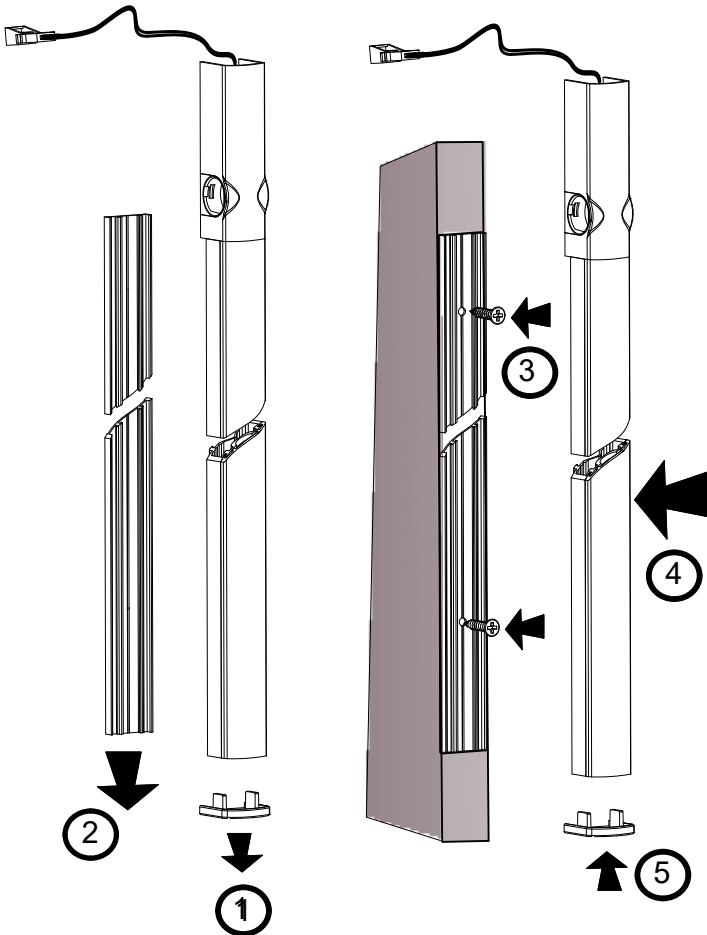

3-B MONTAGE DU COULI-LIGHT SUR JOUE (TYPE B)

INSTALLATION PAR DOUBLE FACE

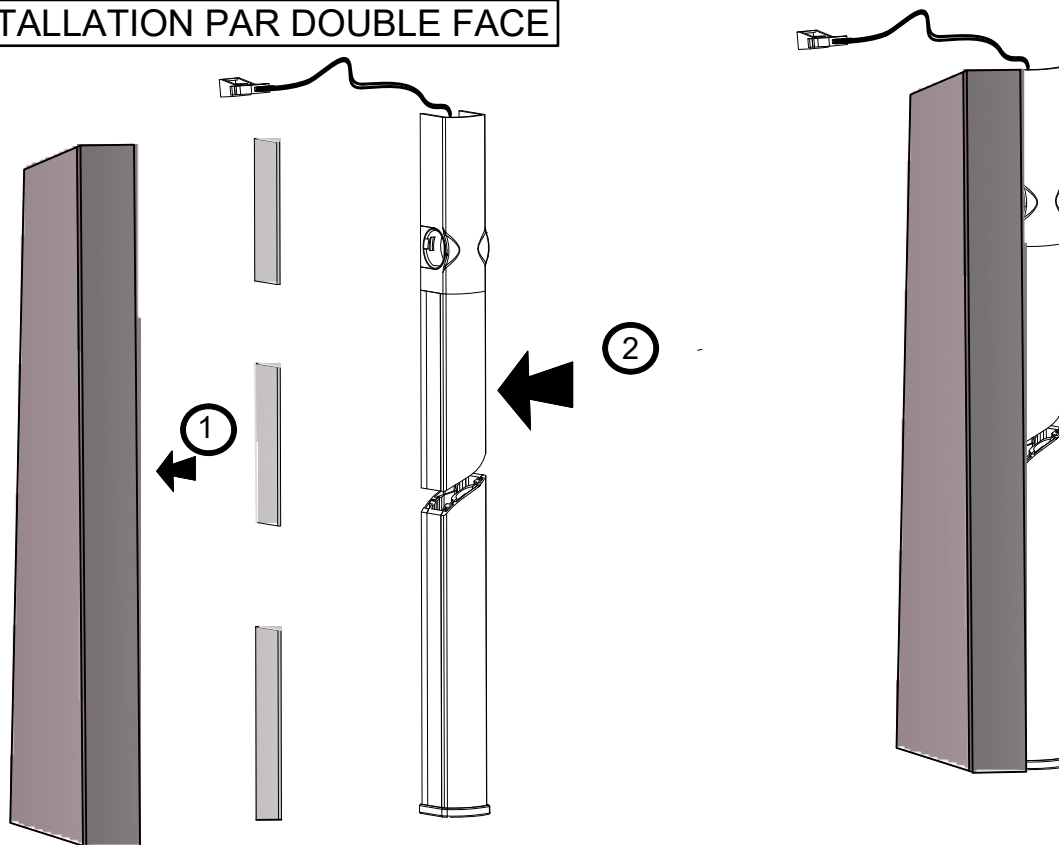

4 MISE EN PLACE DES DETECTEURS



IMPORTANT !
Positionner le
détecteur tête en bas

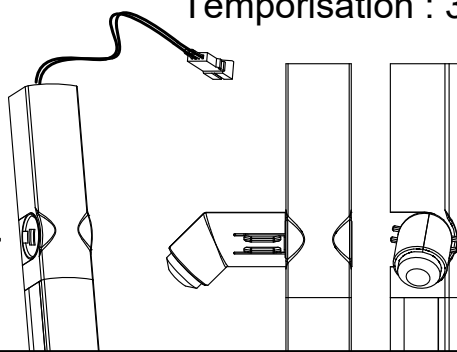
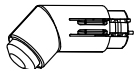

Temporisation : 30s

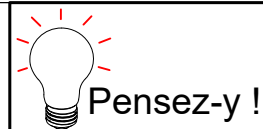

La distance de
détection peut être
réduite en tournant
le détecteur de 5°
vers l'intérieur.

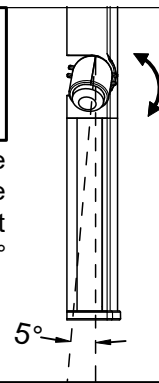

4.B Mise en place Shunt



Attention à la
position les
broches
doivent touché
les zones de
contact

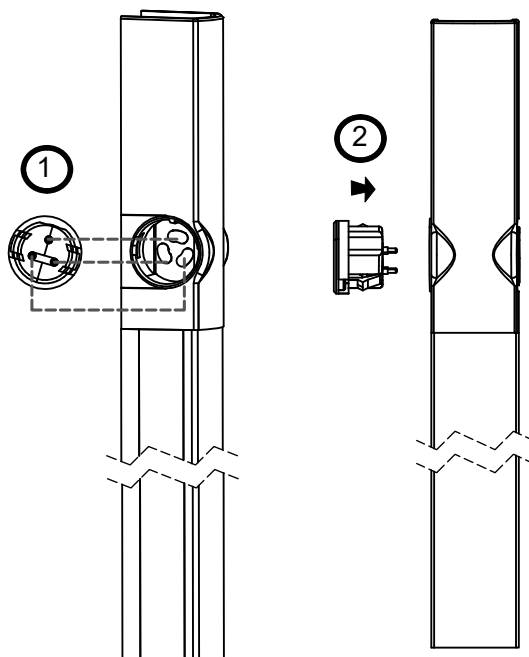

5 BRANCHEMENT DE L'INSTALLATION

